



PTi4500 4500W DIGITAL GENERATOR

Inverter Generator



ATTENTION! You must not start up this machine before you've read the operating manual, adhered to all instructions and the machine is fully assembled according to the instructions!

OPERATING INSTRUCTIONS

CONTENTS

Specifications.....	3
Preamble.....	4
Intended use.....	5
Meaning of the used symbols.....	5
Safety instructions.....	8
Residual risks.....	11
List of components.....	12
Before operation.....	16
Operation.....	18
Maintenance.....	23
Transport and storage.....	27
Troubleshooting.....	28
Disposal.....	30
Warranty.....	31
Notes.....	33

Introduction

Your new POWERTEC Generator will more than satisfy your expectations. It has been manufactured under stringent quality standards to meet superior performance criteria. You will find your new tool easy and safe to operate, and, with proper care, it will give you many years of dependable service.

Carefully read through this entire Instruction Manual before using your new POWERTEC Generator. Take special care to heed the cautions and warnings.

Your generator has many features that will make your job faster and easier. Safety, performance, and dependability have been given top priority in the development of this tool, making it easy to maintain and operate.

Environmental Protection

Recycle unwanted materials instead of disposing of them as waste. All tools, hoses and packaging should be sorted, taken to the local recycling centre and disposed of in an environmentally safe way.



Scope Of Product

This product is suited for home, camping and emergency power applications. It will operate most powertools, appliances and lighting.

Description Of Symbols

The rating plate on your tool may show symbols. These represent important information about the product or instructions on its use.



Wear hearing protection.
Wear eye protection.
Wear breathing protection.

**5405**

Conforms to relevant standards for electromagnetic compatibility.

Specifications

Engine Start	Recoil/Electric
Running Watts	4200W
Peak Watts	4500W
kVA	5.6
AC voltage	230V
AC Frequency	50/60Hz
Fuel Tank Capacity	13L
Running Time	9.2hrs @ 50% load
Noise Level:	68dBA@ 7m, 50% load
Engine Displacement	223cc
Max Current	18.26A
Outlets	2x 15A 230V
Oil Capacity	0.6L
Engine Type	4 Stroke OHV
Machine dimension (LxWxH)	477 x 440 x 493mm
Net Weight	29.5kg
Engine Max Power	9HP
Protection Class	IP23M

PREAMBLE

Thank you very much for purchasing a POWERTEC branded product.
Read the operating instructions carefully before starting up the device.

Reading, understanding and following the safety instructions make a decisive contribution to your safety and protect you from damage to health.

Defective machine parts must be replaced immediately before the machine is put into operation again.

Unauthorized changes to the device exclude the manufacturer's liability for any resulting damage!

If the device is used for improper use, the seller and the manufacturer dissociate themselves from any guarantees!

POWERTEC is constantly working on the further development of its products and therefore reserves the right to make changes without prior notice, e.g. of shape or appearance.

ATTENTION

The device does **NOT** contain any operating fluids on delivery!

We recommend that the device is always transported in an upright position, taking care that it does not fall over.





Otherwise oil can get into the cylinder, the combustion chamber or the air filter, which leads to starting difficulties.



INTENDED USE







The device is suitable for applications which are intended for operation on 230 V ~ and 12 V / 5 V DC. It generates electrical energy as part of a grid replacement operation. The device may only be used within the specified voltage and power limits. It must not be connected to the energy distribution systems (e.g. the public power supply). The generator is not designed for commercial use. It is essential that you observe the restrictions in the safety instructions.

The machine may only be used as intended. Any other use beyond this is not as intended. The user / operator and not the manufacturer is liable for any damage or injury of any kind resulting from this.

MEANING OF THE USED SYMBOLS

SYMBOL	MEANING
	PROHIBITION IN GENERAL (in connection with other pictograms)
	SAFETY- AND WARNINGSYMBOLS Shows danger, warning or reason for caution. Can be used in connection with other symbols or pictograms.
	DANGER Highest risk for mortal danger, respectively a risk of serious injuries if the instructions are not respected!
	WARNING Mortal danger, respectively a risk of dangerous injuries if the instructions are not respected!
	CAUTION Slight or average risk of injuries if the instructions are not respected!

<p style="text-align: center;">NOTICE</p>	<p>NOTICE Risk of damaging the engine or other properties, if the advices are not respected!</p>
<p style="text-align: center;">ATTENTION</p>	<p>ATTENTION Important clauses in the manual are marked with this sign!</p>
	<p>READING THE MANUAL Not obeying the operation instructions or protective measures can cause serious injuries. Read the manual before starting or using the machine</p>
 	<p>WARNING OF CUT INJURIES Only touch machine parts if they came to a standstill</p>
 	<p>WARNING OF HOT SURFACES The silencer reaches a high temperature during operation and also cools down slowly after the device is turned off. Do not touch the silencer when it is hot. Let the generator cool off before it is stored in the house. Minimum distance to fixed objects has to be at least 1m.</p>
 	<p>WARNING OF EXHAUST FUMES The exhaust fumes of the device contain carbon monoxide, a colour and odourless gas. Do NOT operate the device in closed rooms! ALWAYS ensure sufficient ventilation of the location!</p>
	<p>WARNING OF ELECTRIC SHOCK NEVER connect more than one plug to a power socket in order to avoid electric shock!</p>

	<p>GROUNDING In order to avoid electric shock, the generator should only be operated with a strong, grounded cable.</p>
	<p>DO NOT CONNECT THE GENERATOR WITH OTHER CIRCUITS.</p>
	<p>FIRE, OPEN FLAMES AND SMOKING ARE FORBIDDEN. Fuel and oil are inflammable and may explode.</p>
	<p>WARNING AGAINST EXPLOSIVE SUBSTANCES.</p>
	<p>WARNING OF FLAMMABLE SUBSTANCES.</p>
	<p>SOUND POWER LEVEL.</p>

SAFETY INSTRUCTIONS

Keep your work place tidy.

- Disorder at the work place can result in accidents.

Take environmental influences into account.

- Never work with the engine device in closed or poorly ventilated rooms.
- When the engine is running, toxic gases are generated.
- These gases are odorless and invisible.
- Do not expose the power tool to the rain.
- Do not use the power tool in a damp or wet environment.
- Make sure you are standing safely on uneven ground.
- Pay attention to open shafts, trenches and excavations.
- Provide good lighting when working.
- Do not use the power tool in highly flammable vegetation or where there is a risk of fire or explosion.
- Provide fire extinguishers in dry conditions (risk of fire).

Keep other people away.

- Do not let other people, especially children and adolescents touch the power tool. Keep them away from your work area.

Store unused tools safely.

- Unused tools should be stored in a dry, high or locked place, out of the reach of children.

Do not overload your machine.

- You work better and safer in the specified performance range.

Use the right tool.

- Do not use underperforming tools for heavy work.
- Use the tool only for the purposes for which it was built.
- Always keep the tool clean.

Do not leave any tool wrenches inserted.

- Before switching on, check that keys and adjustment tools have been removed.

Be attentive.

- Pay attention to what you are doing. Use common sense while working. Do not use power tools if you are not concentrated.
- **NEVER** work under the influence of alcohol, drugs, medication or other substances that can impair eyesight, dexterity and judgment.

Refueling.

- The engine must **always** be switched off before refueling.
- Always open the fuel cap carefully so that the existing overpressure can slowly dissipate.
- Working with the machine creates high temperatures on the housing. Let the machine cool down before refueling.
- The fuel could ignite and cause severe burns.
- Make sure that the tank is not filled with too much fuel. If you spill fuel, remove it immediately and clean the device.
- Close the screw plug on the fuel tank well to avoid loosening due to vibrations during work.

⚠ DANGER

Wearer of a cardiac pacemaker are not allowed to touch conducting parts of the ignition system with running engine. **MORTAL DANGER!**

Check the power tool.

- Before further use of the power tool, protective equipment or slightly damaged parts must be carefully checked for their proper and intended function.
- Check whether the moving parts function properly and are not jammed or whether parts are damaged. All parts must be correctly assembled and meet all conditions to ensure the correct operation of the power tool.
- Damaged protective equipment and parts must be repaired or replaced by a recognized specialist workshop, unless otherwise stated in the instructions for use.
- Defective switches must be replaced at a customer service workshop.
- Do not use any power tools where the switch cannot be turned on and off.

Use only approved parts.

- This machine complies with the relevant regulations.
- Repair may only be carried out by an authorized service center or our service team using original spare parts; otherwise accidents can occur to the user.

⚠ WARNING

- The use of other parts and accessories not expressly recommended may result in a risk of injury to you.

Working safety instructions

Children and young people under 18 years of age are not allowed to operate the machine. Young people aged 16 and over may use the machine as part of a training course and under the supervision of a trained person.

Read the operating instructions carefully and become familiar with the operating elements. Incorrect operation or operation by inexperienced persons can be dangerous.

NEVER

- use the device for applications for which it is not intended.
- touch the engine or exhaust while the engine is running or shortly after turning it off.
- these areas become very hot and can cause burns.
- leave the device running unattended.

ALWAYS

- use original accessories. The use of other tools and other accessories can lead to unforeseeable machine damage or a risk of injury to you.
- limit the work area and keep members of the public and unauthorized personnel away.
- ensure that the operator is familiar with the appropriate safety precautions and operating procedures.

ATTENTION**ALWAYS**

- turn off the engine when not in use.
- close the fuel tap when the machine is not in operation.
- use the device as intended.
- be sure that the machine will not tip, slide, roll or fall.

- store the machine properly when not in use. Choose a safe location so that the machine cannot be started by unauthorized persons. Do not place the device unprotected outdoors or in a damp environment.
 - Before starting up, inspect protective equipment for its proper and intended function. Check whether the moving parts function properly and are not jammed or whether parts are damaged. All parts must meet all the conditions to ensure the proper operation of the device.
 - damaged protective equipment and parts must be repaired or replaced by a recognized specialist workshop, unless otherwise stated in the instructions for use.
- read the operating instructions before starting up. Instructions on dangers, warnings and precautionary measures must be followed to minimize the risk of personal injury and property damage as well as incorrect servicing.
- **NEVER** use the choke lever to stop the engine.

Safety when using internal combustion engines

DANGER

Internal combustion engines pose a particular danger during operation and when refueling. Always read and heed the warnings and safety instructions given later in this manual. Failure to do so can result in serious or even fatal injuries.

- **DO NOT** run the machine indoors, in garages, deep trenches, or in enclosed areas. The engine exhaust contains toxic carbon monoxide. Staying in an environment containing carbon monoxide can lead to loss of consciousness and death.
- **DO NOT** operate or refuel the device near an open flame.
- **DO NOT** smoke while refueling or operating the device.
- **ALWAYS** check the fuel lines, fuel cap and fuel tank for leaks or cracks. The device must not be put into operation with such damage.
- Make sure that you **ALWAYS** put on the fuel cap and close it well after refueling.
- **ALWAYS** store fuels in a special container away from heat and sources of ignition.

Service security

WARNING

Improper maintenance or failure to observe or correct a problem can become a source of danger during operation. Only operate regularly and correctly maintained machines. This is the only way to assume that you are operating your device safely, economically and without problems for a long time.

NEVER

- clean, maintain, adjust or repair the device while it is running. Moving parts can cause serious injuries.
- let the device run without an air filter.
- use gasoline or other flammable solvents to clean machine parts. Vapors from fuels and solvents can explode.
- store flammable material near the device or the silencer, there is a high risk of fire.

ALWAYS

- disconnect spark plug connector before maintenance, cleaning or repair work. This prevents unintentional starting.
- after repair and maintenance work, put the protective and safety equipment back on the device.

- pay attention to the safe operating condition of the machine, in particular check the fuel system and the tank cap for leaks.
- make sure that the nuts and Screw are properly tightened.
- replace damaged or worn machine parts with new original spare parts.
- remove dirt from the engine cooling fins.
- keep the machine clean and replace damaged stickers if necessary.

RESIDUAL RISKS

Due to the construction determined by the intended use, residual risks still exist even when used as intended in compliance with all relevant safety regulations. Residual risks can be minimized if the 'Safety instructions' and the 'Intended use' as well as the operating instructions as a whole are observed.

Consideration and caution reduce the risk of personal injury and damage.

Neglect of ergonomic principles

- Human behavior, wrongdoing
- Wear prescribed protective equipment.
- Always be fully concentrated on all work.
- Residual risk - can never be excluded.

Risk of burns:

Touching the muffler, the exhaust and other heatable machine components can cause severe burns.

Risk of electric shock:

The generator produces energy. Misuse can result in electric shock.

Furthermore, despite all the precautions taken, there may be residual risks that are not obvious.

LIST OF COMPONENTS

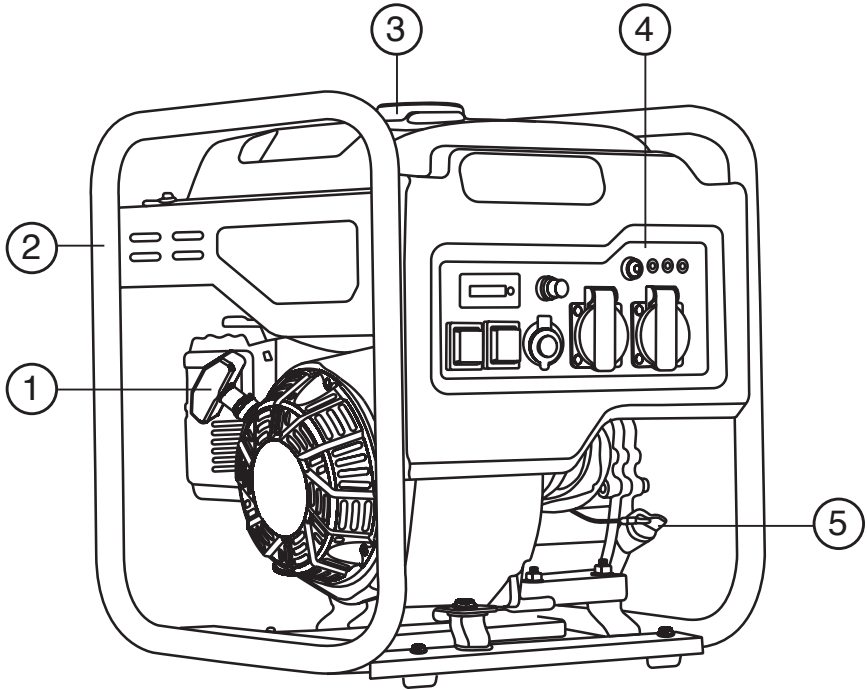

1. Manual starter
2. Frame
3. Fuel tank cap
4. Control panel
5. Oil-depth gage

Control element

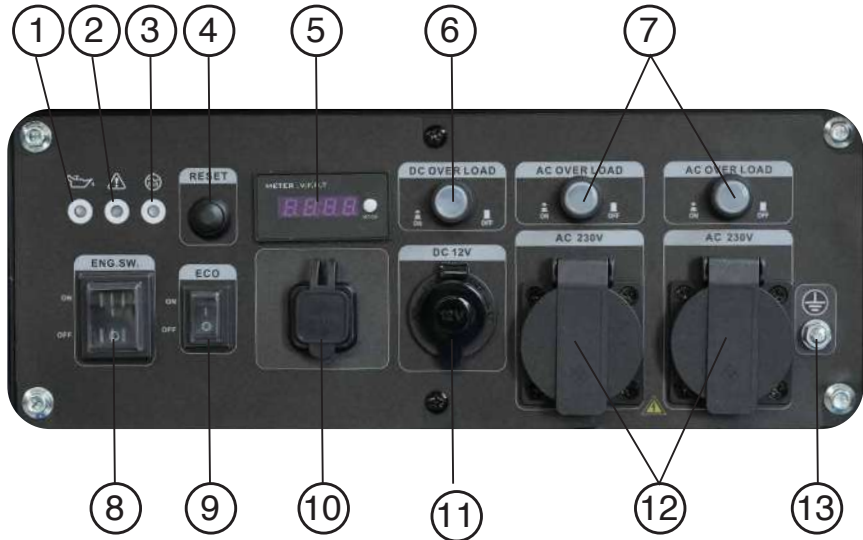

- | | |
|-----------------------|--------------------------|
| 1. Low Oil Indicator | 7. AC Overload |
| 2. Overload Indicator | 8. Engine Switch |
| 3. Running Indicator | 9. Economy Mode Switch |
| 4. Reset Button | 10. USB Ports |
| 5. LED Display | 11. 1x12V DC Outlet |
| 6. DC Overload | 12. 2x15A230V AC Outlets |

13. Earthing Bolt

Operation indicator

The operation indicator lights up as soon as the generator is started. During optimal operation, the operation indicator lights up continuously. The indicator goes out in case of overload or when the generator is switched off.

Overload display

230 V-sockets:

- in case of OVERLOAD it will be indicated by the the light in the middle
- in case of overload turn the main switch into position 'OFF' and remove connected devices
- afterwards restart the generator

ATTENTION

If this happens, reduce the electric power you are taking from the generator or remove any defective connected appliances.

Overload or malfunction of the consumers

ATTENTION

Inductive consumers require more power for start-up. So ensure that you don't exceed the rated power with the consumer you use.

Inductive loads (certain devices which are powered by an electric engine, e.g. drill hammers, circular saws, chainsaws, compressors and pumps) are consumers, which can only provide c. 70% of their input power as output power on account of winding and friction losses. In addition, the engine needs power for starting up, which is three to six times as high as the power rating of the device, depending on model and quality of the engine. In case of doubt, we recommend a generator with larger capacity, especially if the devices to be connected are of old design or engines with low efficiency, which need higher-than-average starting currents. Please check the starting current for the particular load you wish to connect with the respective manufacturer

DC reset

The DC reset overload switch is located in the immediate vicinity of the DC socket. This monitors the 12 V socket (DC socket) and by pressing the switch the associated socket can be released again (after overload shutdown).

If an overload occurs, the 12 V DC connector will be isolated from the supply. The 12 VDC connector can be reconnected by pressing the overload switch (DC-Reset).

ATTENTION

The 12 V DC socket can only be charged with 100 W max.

USB ports

The USB ports (type A) allow the output of 5 V. The maximum amperages are 2.1 A and 1 A.

The output of 5 V is provided by USB ports of type A. Accordingly, these ports may only be used with type A plugs. These ports allow a maximum current of 2.1 A and 1 A.

CAUTION

The USB ports may only be used with type A plugs.

Oil lack display

The oil warning system protects the generator against damages caused by too low oil level in the engine case. Before the minimum filling level is undershot, the system automatically turns off the engine (the main switch stays on position 'ON').

If you want to restart the engine after a stop by the oil warning system, pay attention to the oil lack display. If it is red, the motor cannot be started. In this case, fill up the oil.

ECO-SWITCH (SELECTOR SWITCH GAS SAVING MODE)

With the selector switch gas consumption can be restricted and noise can be reduced, if less power is needed. The generator regulates now the rpm according for the required power.

⚠ CAUTION

- The fuel-saving mode is not suitable for applications in which loads require energy very quickly (inductive loads).
- If several loads with high power requirements are connected, set the fuel-saving mode selector switch (ECO switch) to the 'OFF' position.
- If the generator runs constantly, set the fuel-saving mode selector switch (ECO switch) to the 'OFF' position.
- Effective protection against electric shock is only provided by circuit breakers that are specifically designed for the generator. When using circuit breakers, ensure that they have the same rating and performance characteristics.
- Due to the high mechanical strain, only resilient flexible cables with rubber jacket or similar materials should be used (acc. to IEC 245-4).

AC-power-outlets

The AC-power-outlets have a 230 V connection and supplies alternating current to the connected device. The generator outputs the current at a frequency of 50 Hz.

DC-power-outlet

Devices connected via the DC-power-outlet receive direct current through a 12 V connection (max. 100 W).

Connecting to earth

The housing is allowed to be connected to earth in order to discharge static electricity. To do this, connect one end of a cable to the earth connection on the generator and the other end to an external earth (for example an earthing rod).

AC reset

The AC reset is a bi-metal switch and is responsible for securing the AC socket (230 V). By pressing the button, the respective sockets can be enabled again (after overload disconnection).

BEFORE OPERATION

Fill engine oil

The generator is delivered without oil. Please pay attention to the following advices for the choice of the oil.

ATTENTION

Check whether the device is standing horizontally and the main switch is on.

When filling, make sure that the appliance is not tilted.

The motor oil has great influence on the lifetime and performance of the engine. Only use four-stroke oil!

We recommend SAE 10W-40 for daily use for all temperatures.

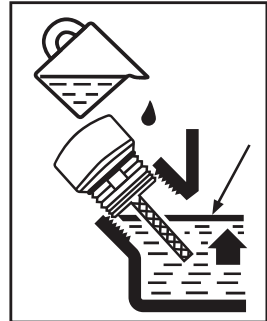
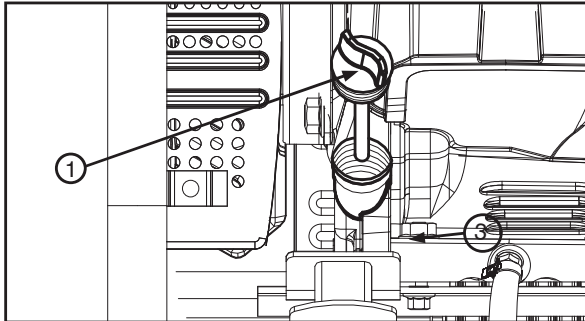

Please fill in the engine oil (approx. 0.55 l) until the oil level reaches the upper edge of the filler neck.

ATTENTION

Operation at too low oil level can destroy the generator.

NOTICE

The oil warning system protects the generator against damages caused by too low oil level in the engine case. On reaching the oil level reaches the minimal filling level, the oil lack display will light up and the system will automatically turn the engine off (the main switch remains on the ON position, if it was turned into ON position before). If the engine is turned off, or the oil lack display lights up upon switching on the starter, check the oil level first before looking for other faults.

Fill with petrol

- The generator runs on gasoline (E10 also possible).
- Please refill gasoline in case of low gasoline level.
- Never use old or dirty gasoline or an oil-gasoline mixture.
- Avoid dirt and water entering the gasoline tank.

NOTICE

Regular gasoline usually has a shelf life of 3 months.
Alternatively, the gasoline type / special fuel ASPEN4 can be used.

⚠ WARNING

- Gasoline is highly inflammable and may explode under certain circumstances.
- **DO NOT** smoke and avoid open fires and sparks during filling of the gasoline tank as well as at the storage location of the gasoline. Fill up the fuel tank only at well-aerated locations and when the device is turned off.
- **DO NOT** overfill the tank (gasoline level must be lower than the upper marking).
- **DO NOT** spill gasoline during filling. Spilled amounts and gasoline vapours may catch fire. In case of spilled gasoline, make sure that the vapours evaporate before the generator is turned on.
- Avoid long skin contact with gasoline and breathing in gasoline vapours.

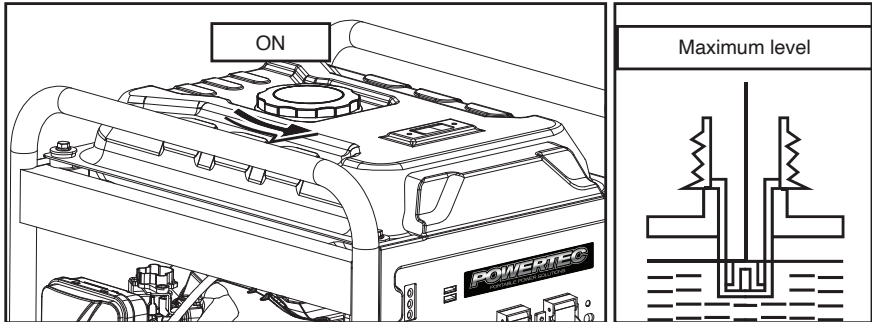

OPERATION

Make sure that no consumer is connected and the generator is leveled out. To avoid overheating, assure that the ventilation under the generator is guaranteed.

1. Turn the ECO-switch into position 'OFF'.

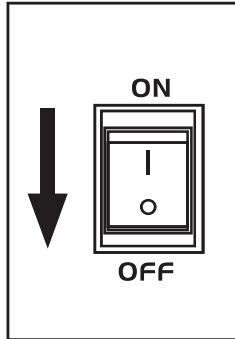

2. Turn the power switch into position 'ON'.

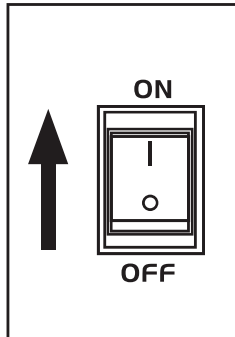

3. Turn the fuel tap into position 'ON'.

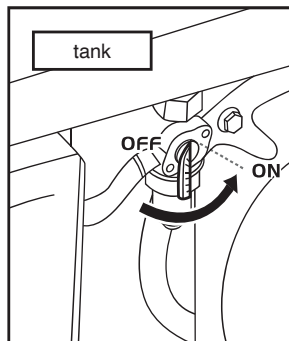

4. Move the choke to the closed position.

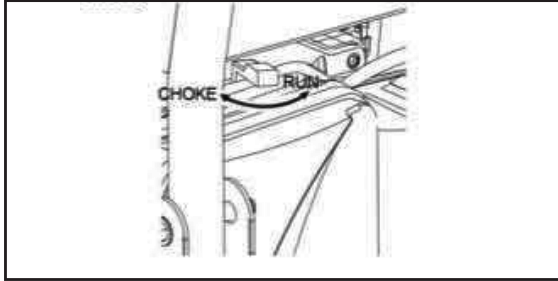

5. Slightly pull the starter until you can feel a resistance, then pull hard.

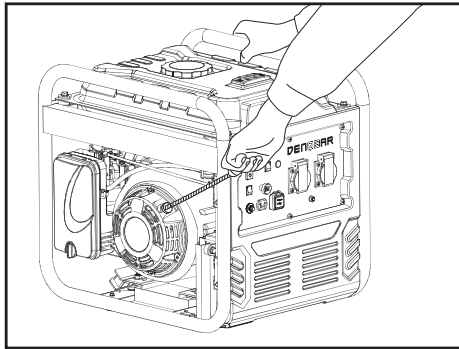

ATTENTION

Make sure that the handle of the cable wire starter does not recoil against the generator case. Carefully lead the handle back to avoid damages to the handle or case.

6. If the choke was in the 'CLOSE' position when the engine was started, slowly move the choke back to the 'OPEN' position after starting.

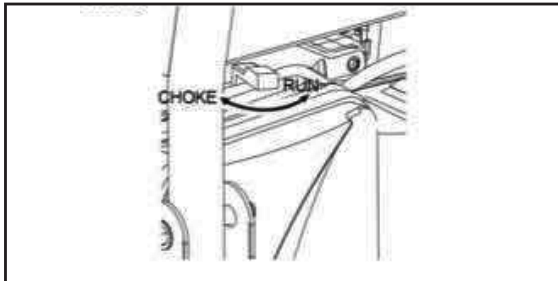

NOTICE

If the engine cannot be restarted after it has been turned off, please check the oil level first.

ATTENTION

Modifications to the carburetor for the operation in high altitudes can cause overheating and massive damages to the device.

Areas of use**⚠ WARNING**

In order to avoid electric shock, the generator should only be used with a strong, grounded cable. For example, you can use a commercially available earth rod for grounding. As a cross-section of the protective conductor, we recommend 2 times the wire diameter of the connection cable with a maximum length of 20 meters. The specifications of the connection cable are usually printed on the cable.

ATTENTION

- **Avoid exceeding the rated power during constant operation of the generator. Otherwise please consider the total consumption of the connected devices.**
- **DO NOT operate the generator above the rated power. In this case, the seller, as well as the manufacturer gives no warranty.**
- **DO NOT connect the generator to the house power circuit, as this may destroy the generator or electric devices in the house.**
- **Use the generator ONLY for its designated purpose.**
- **Only use authorised and marked cables for line extension (H07RN...)**
- **Maximum line length incl. extension: 50 m for cable with 1.5 mm² diameter, 100 m for cable with 2.5 mm² diameter.**
- **Keep the generator away from other electric lines, for example manifold.**

NOTICE

- *You may use direct current and alternating current at the same time. Pay attention that the power consumption does not exceed the admissible total power of the generator.*
- *The power consumption of the connected consumers upon start-up may not exceed the rated power of the generator. In this case, the seller as well as the manufacturer gives no warranty.*

Use of alternating current (AC)

1. Turn on the device and check that the operating display lights up.
2. Ensure that the desired consumer is turned off and only then insert the power plug of the consumer into the power socket.

ATTENTION

An overload of the generator, indicated by the middle LED light of the operating display may damage the generator.

If the device shows abnormal action, for example slowed reaction or abrupt shut down, it must be turned off immediately. Disconnect the consumer from the generator and check whether the problem is caused by the consumer, or whether the rated power of the generator was exceeded.

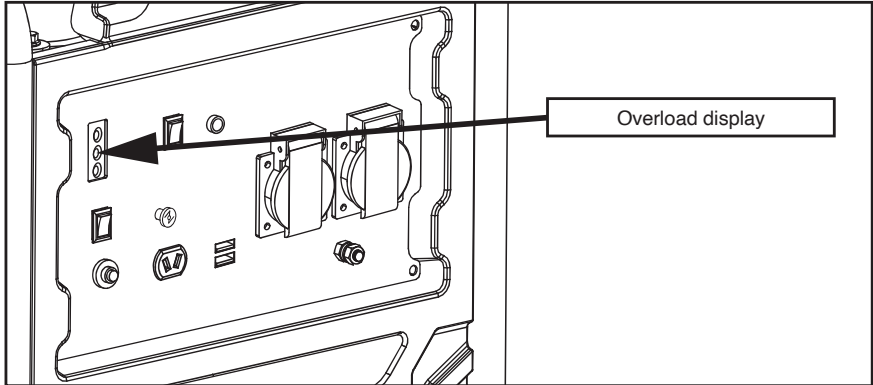

Use of continuous current (DC)

1. Turn on the device and check that the operating display lights up.
2. Ensure that the desired consumer is turned off and only then connect the cable of the consumer with the DC-socket.

Switching off the generator

To turn off the generator in case of emergency, simply set the main switch to position 'OFF'.

Regular operation mode

1. Disconnect any consumer from the generator.

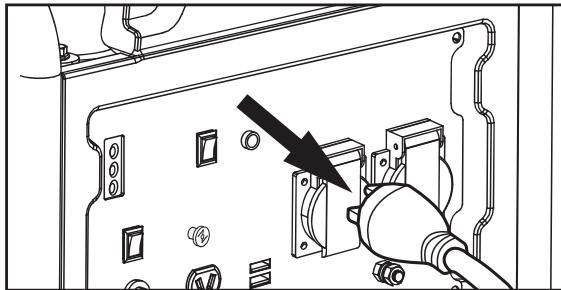

2. Turn the power switch to position 'OFF'.

These steps will turn off the ignition.

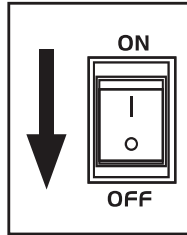

3. Turn the fuel tap into position 'OFF'.

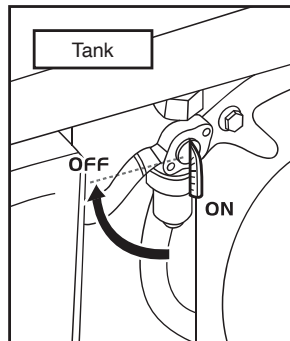

ATTENTION

When switching off, transporting and storing the power generator, make sure that the lid of the petrol tank and the petrol tap are closed and the main switch is in the 'OFF' position.

MAINTENANCE

ATTENTION

Always disconnect the spark plug connector before maintenance work.

Good maintenance of your generator ensures safe, economical and smooth operation. Air pollution is also reduced.

⚠ WARNING

Turn off the generator prior to maintenance.

NOTICE

Use only original for replacement of defective or worn components in order to avoid damage to the generator.

Engine Oil Specification

1. Only use the engine oil Specified in Figure 1.
2. Only use 4-stroke/cycle engine oil. **NEVER USE 2-STROKE/CYCLE OIL.** Synthetic oil is an acceptable substitute for conventional oil.

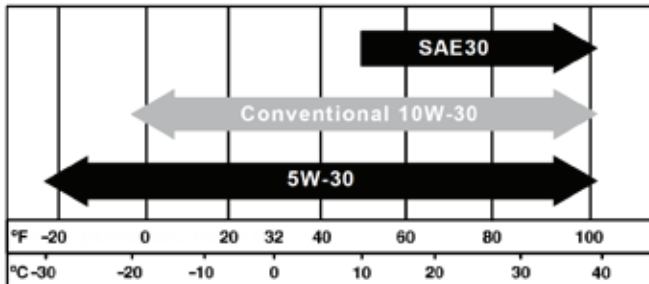

Figure 1 - Recommended Oil

Change engine oil

Drain old oil while engine is still warm. Warm oil drains quickly and completely.

ATTENTION

Turn the power switch into position 'OFF' and close the fuel cap.

- A. Place a suitable container to collect the used oil.
- B. When switching off, transporting and storing the power generator, make sure that the lid of the petrol tank and the petrol tap are closed and the main switch is in the 'OFF' position.
- C. Drain the oil completely.
- D. Ensure that the generator is level, then fill recommended oil to the top of the filler neck (1).
- E. Wash hands with soap and water after handling used oil.

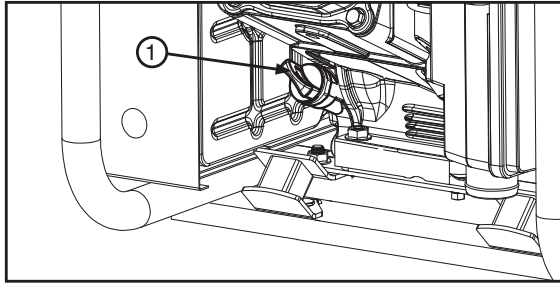
**ATTENTION**

Improper disposal of old oil can cause environmental pollution. If you change the oil yourself, please ensure environmental-friendly disposal. Fill oil into a lockable container and take it to the collecting point. Do not dispose in waste or onto ground or into the drain.

Maintenance of air cleaner

A dirty air cleaner influences the air inflow of the carburetor. Service the air cleaner regularly to avoid a malfunction of the carburator. Shorter maintenance intervals are necessary if the generator is operated under very dusty conditions.

⚠ WARNING

Never use gasoline or inflammable solvents to clean the air filter. This could cause fire or explosion.

- A. Loosen the screw.
- B. Remove the air filter.
- C. Thoroughly wash the air filter with warm soapsuds and rinse or clean with non-combustible solvent or solving agents with high flash point. Let it dry.
- D. If necessary, replace the air cleaner.

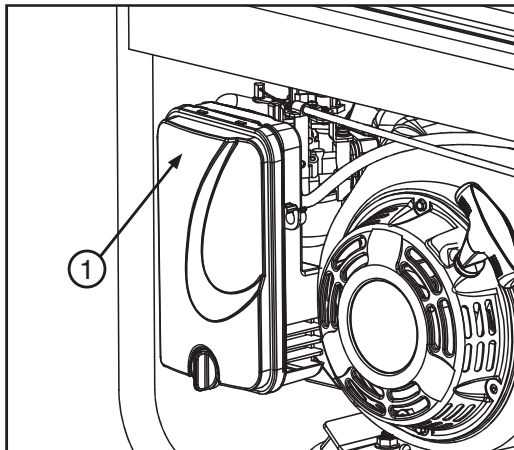

Spark plug maintenance

Use only an original high-quality spark plug.

To ensure smooth operation of the engine, the spark plug must be free of sediments and the electrode intervals must be adjusted correctly

1. Remove the spark plug cap (1).
2. Remove spark plug (2) with a spark plug spanner.

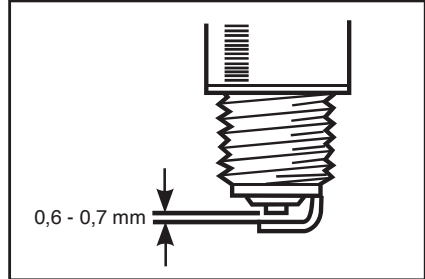
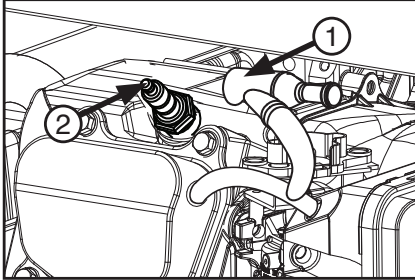

3. Check spark plug visually. Dispose of plugin case of damage or splattered places on the isolator.
4. Measure electrode intervals with an adequate gauge. The interval should easure 0.7 - 0.8 mm.
5. Ensure that the sealing ring of the spark plug is in good condition. Screw in spark plug by hand in order to avoid tearing of the thread.
6. After screwing the spark plug in, tighten the plug with a spark plug spanner (22 Nm) to compress the sealing ring.
7. Fix the spark plug connector 2 back tightly onto the spark plug.

ATTENTION

The spark plug must be screwed in tight (22 Nm), otherwise it will get hot and can damage the generator.

Maintenance plan

Regular maintenance at the stated times or after according hours of operation (choose earlier date)		Before every use	Monthly or every 10 hours	Every 3 months or every 50 hours	Every 6 months or every 100 hours	Yearly or every 300 hours
Maintenance item						
Oil level / gasoline	Check	<input type="checkbox"/>				
	Change		First time	<input type="checkbox"/>		
Air cleaner	Check		<input type="checkbox"/>			
	Clean			<input type="checkbox"/>		Change
Spark plug	Clean		First time		<input type="checkbox"/>	Change
Visual inspection		<input type="checkbox"/>				
Silencer screen	Check			<input type="checkbox"/>		
	Clean				<input type="checkbox"/>	

TRANSPORT AND STORAGE

ATTENTION

Unplug the ignition coil before transport and storage.

In order to avoid gas leakage during transport and storage, please turn the power switch and the fuel cap to 'OFF' and place the generator at an elevated level.

⚠ WARNING

Please pay attention to the following notices during transport:

- **DO NOT** overfill the gasoline tank, but only to the maximum level.
- **DO NOT** operate the generator in a truck or in another vehicle, but only on firm ground at a well-aerated location.
- Protect the generator against sun during transport as in a closed container the high temperatures may emit gases which may catch fire.
- **DO NOT** transport the generator over uneven streets for longer periods of time. If this is unavoidable, please empty the gas tank completely.

Prior to a long-term storage of the generator:

NOTICE

Our generators can be stored as emergency generators.

To do so, the oil should be drained first, and then the gasoline should be drained or dumped. You can also use a small hand pump to drain the gasoline if available.

NOTICE

Please fill with fresh operating fluids when using again.

For this purpose, all operating fluids should be drained. Otherwise, there is a risk that components of the oil or gasoline will settle and impair the functionality or the engine will not start at all.

The fuel tap, for example, can be closed during the last run, so that the device stops due to lack of gasoline and there is no more gasoline in the lines, the gasoline filter or in the carburetor.

Connected consumers do not start

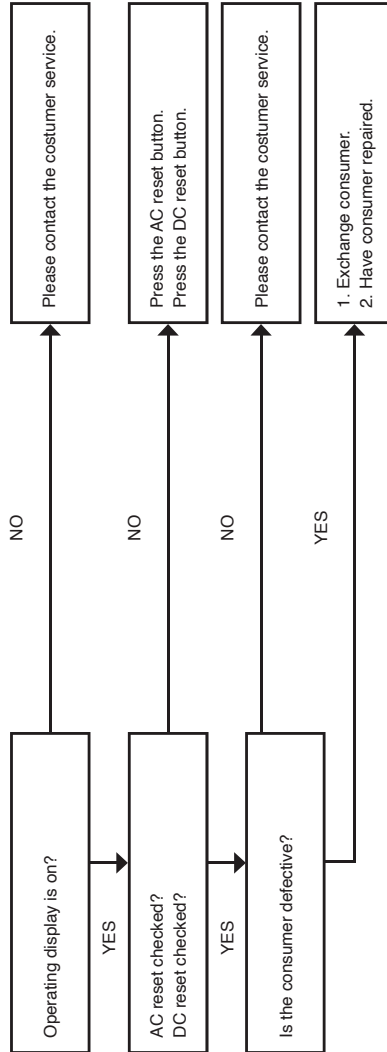

DISPOSAL

Dispose the sweeper

Risk of fire or environmental damage! Avoid damage caused by leaking operating supplies: drain the operating supplies prior to disposal! This generator must not be disposed of with regular household waste! Dispose of the generator in the appropriate manner. For more information, consult your community waste disposal service. Items which are labelled with the adjacent symbol must not be disposed of in household waste. You must dispose of such old electrical and electronic equipment separately. Through separate disposal you send old equipment for recycling or for other forms of re-use. You will thus help to avoid in some cases that damaging materials get into the environment.



Dispose the packaging

The package protects the appliance against damage during transport. Packing materials are usually chosen depending on their environmental friendliness and disposal method and can therefore be recycled. Returning the package to material circulation saves raw materials and reduces waste disposal costs.

ATTENTION

Parts of packages (e.g. foils, styrofoam) can be dangerous to children. Risk of suffocation! Keep parts of packages away from children and dispose them as soon as possible.

Warranty

As part of an on-going commitment to excellence in product support, Euroquip offers a comprehensive product warranty program.

1. THIS WARRANTY:

The benefits provided to the consumer in this warranty are in addition to other rights and remedies of a consumer under the New Zealand Consumer Guarantees Act 1993 and any other laws in relation to the products to which this warranty relates. This warranty:

- Covers the product against faulty materials or workmanship; and
- Covers the replacement of parts, the repair labour used, a refund of the price of the product or replacement of the machine, or other compensation for the remainder of the warranty period.

This product warranty is only applicable to the original purchaser of the machine and only purchases made from Euroquip Authorized Retailers.

2) WARRANTY PERIODS:

Domestic/Commercial: 12 Months

Or

1000 hours of operation – whichever occurs first.

Domestic Warranty applies to domestic use of the product: Personal, residential, or household use only. Commercial Warranty applies to commercial or business use of the product: All uses other than domestic use, including use for income-producing (including farming) or rental purposes.

*These Powertec Warranty periods are for products that are:

- Serviced by a Powertec Dealer in accordance with the Powertec service schedule, using genuine parts and the correct grade of oil (proof required)
- Meeting all other warranty requirements

NOTE: These warranty conditions apply to New Zealand only.

Euroquip warrants each new Powertec machine free from defect in material and workmanship under normal use and routine servicing, for the warranty periods specified. Conditional to the limitations and exclusions list below. The warranty period begins when the product is purchased by the end user. Warranty is not transferrable and is only claimable by the original purchaser.

Proof of purchase documentation with product serial number must be provided. If it has been lost and Euroquip does not have a record of the purchaser's details, the warranty period shall be calculated from the appropriate dealer wholesale sale date.

The purchaser must keep a record of all service and maintenance history as proof of servicing history. This may be requested when assessing any future warranty claims. The decision that an issue with a product qualifies as a warranty claim is made at the sole jurisdiction of Euroquip.

No costs incurred will be considered under warranty if repairs or maintenance are carried out by any party other than a Euroquip Approved Service Agent, unless with prior consent in writing from Euroquip.

It is the full responsibility of the purchaser to deliver the product under warranty to the nearest relevant service agent or product reseller. Warranty does not cover transportation costs including call outs, mileage and freight costs.

Customers are responsible for the care and cleaning of their product prior to sending it to our service centre. Any product being sent us must be thoroughly cleaned. Depending on what the product has come into contact with, it could pose an Occupational/ Work Health and Safety risk for our staff and/or service agents to inspect, repair or service a product that has come into contact with a hazardous substance. If we are asked to inspect, repair or service a product that has come into contact with a hazardous substance such as chemicals, asbestos or silica dust, we may not be able to inspect, service or repair the product. If this is the case, we will inform the purchaser and the product will be returned.

If a product is repaired under warranty, parts and labour required for the repair will be supplied at no charge. All defective parts replaced under warranty become property of Euroquip. Consumable items such as, but not limited to, oils, coolants, filter and spark plugs shall be the responsibility of the owner. Warranty assessment and repair will be scheduled and executed according to the normal work flow at the service location and depending on the availability of suitable replacement parts.

This warranty policy is an additional benefit and does not supersede the legal rights of any customer, reseller or service agent.

Should any issue be found to be a combination of a warranty failure and a non-warranty issue such as incorrect charging techniques, the repair cost component to rectify and repair the non-warranty failure is the **customer's** full responsibility.

3) EXCLUSIONS:

- Warranty does not cover parts that are subject to wear and tear from usage and/or damage which results from neglect of periodic maintenance.
- Evidence must be provided that the product has been maintained and serviced suitably for a claim to be considered under warranty.
- Batteries supplied with your product are warranted against defect for 3 months and does not include lack of charge due to non-use. Consumable items such as, but not limited to, oils, coolants, filters, spark plugs and batteries shall be the responsibility of the purchaser.
- Failure caused by incorrect operation of the product as specified in the manual either intentionally or by error.
- Lack of proper care and maintenance of the product.
- Any damage which results from unavoidable natural disasters, fire, collision, theft, etc.
- Any normal wear or deterioration, such as that of sliding or rotating parts caused under normal operating conditions.
- Any damage that results from misuse or use beyond the limitations of the products intended purpose (such as overloading or use under abnormal conditions).
- External circumstances such as product deterioration or corrosion due to environmental conditions like heat, cold, salt spray, sand or due to the passage of time
- Normal phenomena such as noise, vibration or oil seepage which are considered by Euroquip as not affecting the quality, function or performance of the product.
- Any damage due to improper storage or transport.
- Consumable replacement items: Spark plugs, contact points, shear pins, fuel strainers, oil filter elements, air cleaner elements, brake shoes or pads, clutch components, fuses, motor brushes, gaskets, tube or hoses, belts, cutting blades, light bulbs, serviceable bearings. Petroleum and others fluids: Oil, grease, battery electrolyte, and radiator coolant. Other items specified by Euroquip.
- Periodical maintenance items such as cleaning, inspection and adjustments.
- Contaminated fuel
- Modifications or installations of other products to the product
- Damage that results from the use of non-genuine parts, lubricant or fluid not approved by Euroquip
- Any repair and/or adjustment to correct improper or poor quality work previously performed.
- Attempted repair/ service by a party other than an Approved Service Agent, or any repair undertaken prior to approval of warranty by Euroquip is not covered under warranty.
- Warranty does not cover pre delivery service and adjustment, or failure that may occur as a result of lack of/ incorrect pre delivery service and adjustment. Warranty does not cover any incidental, indirect or consequential loss, damage, personal injury, or expense that may result from any defect, failure, malfunction, or misuse of a product.
- Any product that is found to have come into contact with hazardous substances such as chemicals, asbestos or silica dust and NOT been industrially cleaned prior to servicing.

4) HOW TO CLAIM WARRANTY:

In the event you are faced with a manufacturing fault with your Powertec product, you can claim a repair or part replacement under warranty if the following conditions are fulfilled:

- The problem is related to production quality or specifications of the machine
- The machine is within the warranty period outlined in schedule
- The issue does not fall within the warranty exclusions listed

If the criteria above is met, and you would like to request a warranty, then please go online to <https://www.euroquip.co.nz/Service-Request-End-User> and log your warranty claim.



Congratulations on your new **POWERTEC** product. We are proud to have you as our customer and will strive to provide you with the best service and reliability in the industry. This product is backed by our extensive warranty and service network. Please contact your local agent or submit a service case online for fast response at www.powertec.net.nz